



Forming The Future™

PATTERN 15005A

Sun Burst

Geometric Pattern

GrayLastic™

Elastomeric Urethane - up to 100 uses.
Mold bonded to 0.75" plywood. Add 1.125" to liner thickness.

Geometric

Part Size: 117.5" W x 24" H

Max Depth: 2"

Pattern matched panels

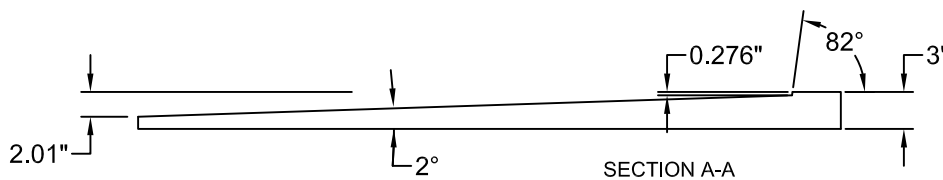
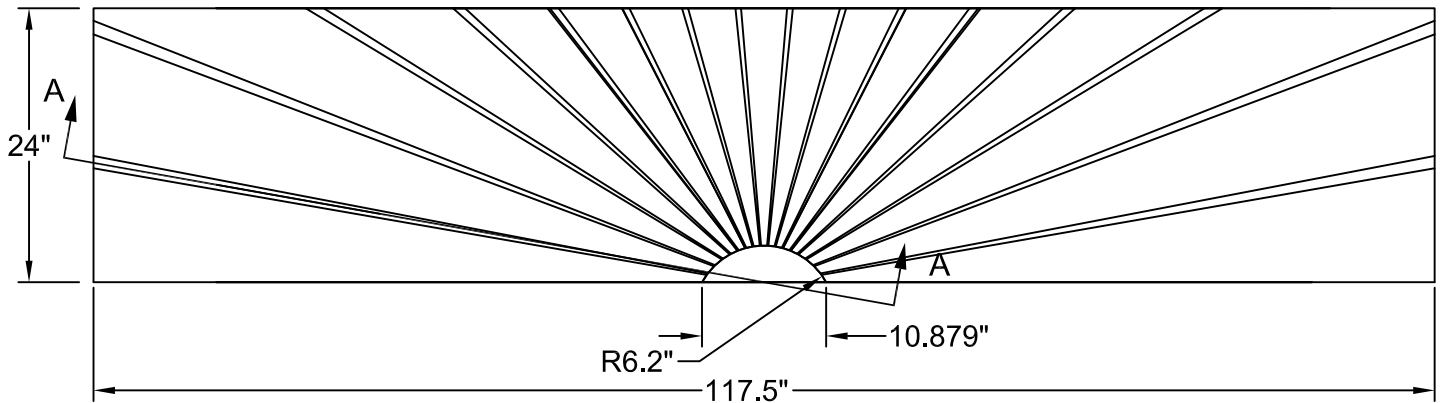
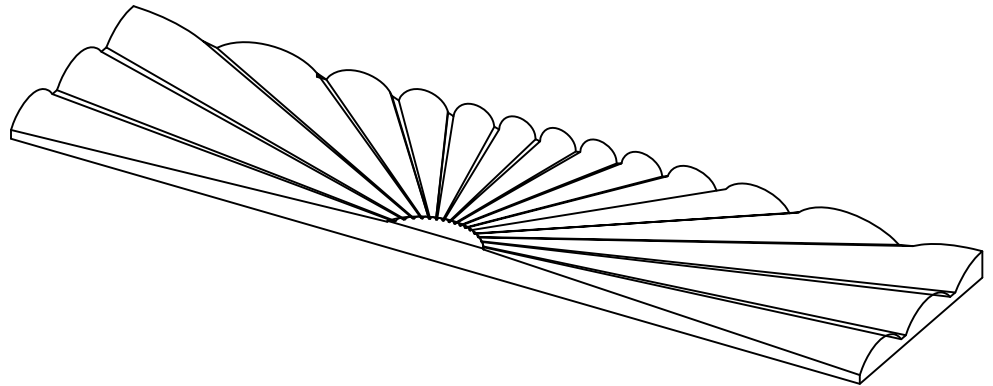

This document contains confidential and proprietary information of Fitzgerald Formliners, Inc. and is protected by copyright, trade secret, and other state and federal laws. Its receipt or possession does not cover any rights to reproduce, disclose its contents, or to manufacture, use, or sell anything it may describe. Reproduction, disclosure, or use without specific written authorization of Fitzgerald Formliners, Inc. is strictly forbidden.

FITZGERALD FORMLINERS

1500 East Chestnut Avenue • Santa Ana, CA 92701

Ph: (800) 547-7760 • Fax (714) 245-9715 • WWW.FORMLINERS.COM

Pattern can be requested in AutoCad format.

File Name: S-15005-GR-10-23-07

Page 1 of 2



Forming The Future™

PATTERN 15005B Sun Burst Pilaster

Geometric Pattern

GrayLastic™

Elastomeric Urethane - up to 100 uses.
Mold bonded to 0.75" plywood. Add 1.125" to liner thickness.

Geometric

Part Size: 8" W x 56" H

Max Depth: 2"

Pattern matched panels

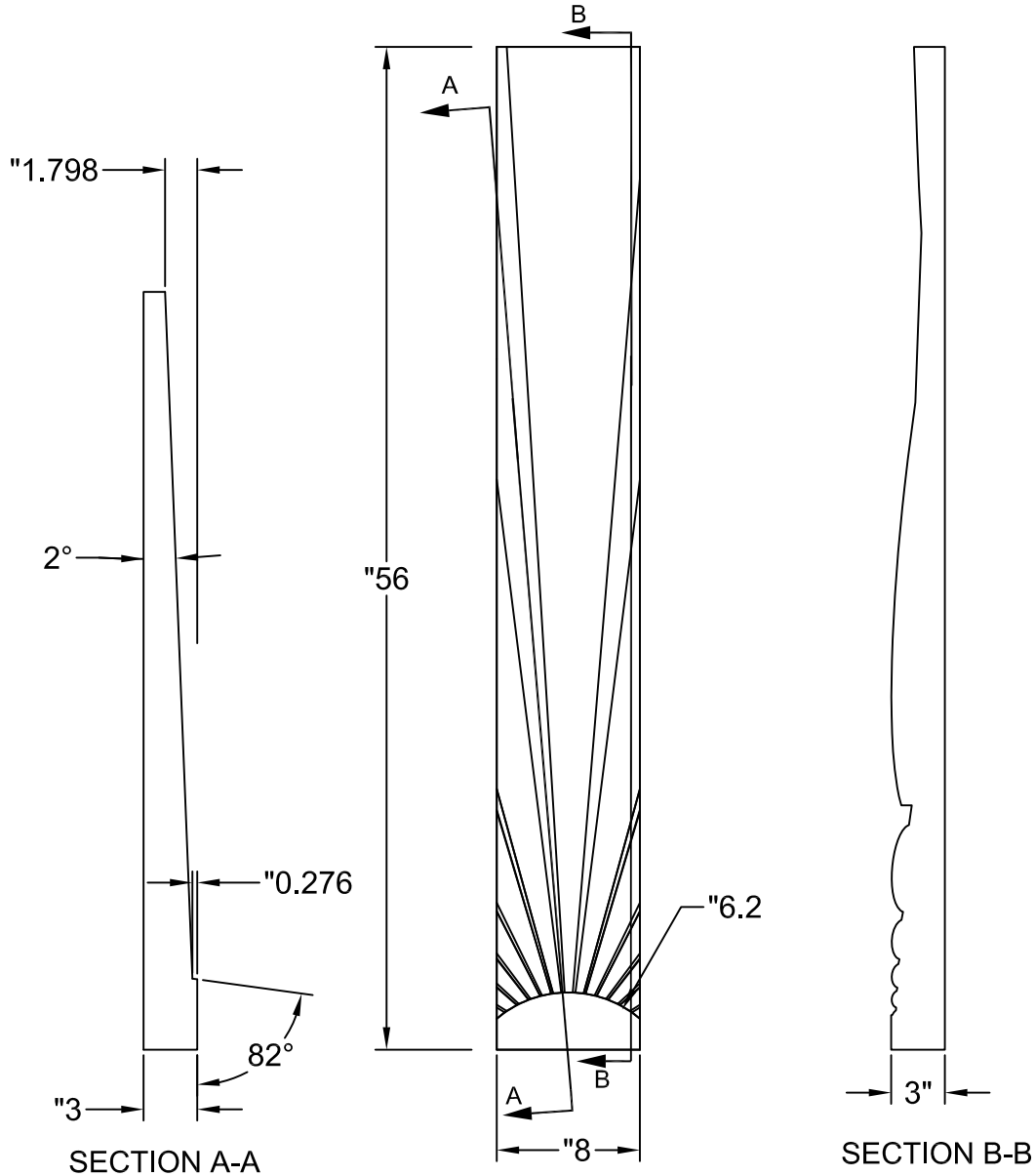

This document contains confidential and proprietary information of Fitzgerald Formliners, Inc. and is protected by copyright, trade secret, and other state and federal laws. Its receipt or possession does not cover any rights to reproduce, disclose its contents, or to manufacture, use, or sell anything it may describe. Reproduction, disclosure, or use without specific written authorization of Fitzgerald Formliners, Inc. is strictly forbidden.

FITZGERALD FORMLINERS

1500 East Chestnut Avenue • Santa Ana, CA 92701

Ph: (800) 547-7760 • Fax (714) 245-9715 • WWW.FORMLINERS.COM

Pattern can be requested in AutoCad format.

File Name: S-15005-GR-10-23-07

Page 2 of 2